



Netter pneumatic maintenance units and their individual components have a considerable influence on the lifetime of Netter's pneumatic vibrators.

Pneumatic piston vibrators cause an air shock, which oscillates back into the pressurised air network.

The maintenance units recommended by **NetterVibration** are designed specially for pneumatic vibrators and have been used successfully for many years. The continual dispersion of the oil guarantees a trouble free operation with all of Netter's pneumatically operated vibrators.

The use in explosion-endangered areas is possible when complying with valid regulations (among others 1999/92/EEC) and the corresponding operating instructions of the operating company. A formally conducted risk assessment resulted in the conclusion that the maintenance units have no potential source of ignition and thus are suitable for use in potentially explosive areas designated as zone 1 and 21.

The maintenance units consist of filter elements with $\leq 5 \mu\text{m}$ filter transmittance. The regulators consist of filter elements with $\leq 40 \mu\text{m}$ to $\leq 5 \mu\text{m}$ filter transmittance

The following data sheets contain a list of those units, which have proved to be technically reliable, both in continuous testing and short periods of operation.

1. Complete maintenance units

Data

Type	Order No.	Nominal diameter/ connection	Perm. pressure range [bar]	Input pressure max. [bar]	Flow [l/min]	Weight [kg]	Filter [µm]
NWE 1/4	81881014	G 1/4	0,5 - 7	16	850	0,66	5
NWE 3/8	81881038	G 3/8	0,5 - 7	16	1.700	1,44	5
NWE 1/2	81881012	G 1/2	0,5 - 7	16	6.800	1,44	5
NWE 1	81881100	G 1	0,5 - 7	16	7.200	2,67	5

All units with manual outlet valve, manometer, lubricator, regulator, connecting angle and filter cartridge

Dimensions [mm]

Type	A	B	C	D	E	F	G	H	I	K	L	M	N
NWE 1/4	211	95	89	95	104	35	4,3	43	72	G ¼	41	19	80
NWE 3/8	268	114	122	128	139	60	5,3	70	102	G ⅜	50	19	85
NWE 1/2	293	126	143	149	160	60	5,3	70	108	G ½	50	19	90
NWE 1	293	126	154	160	171	60	5,3	70	108	G 1	50	19	90

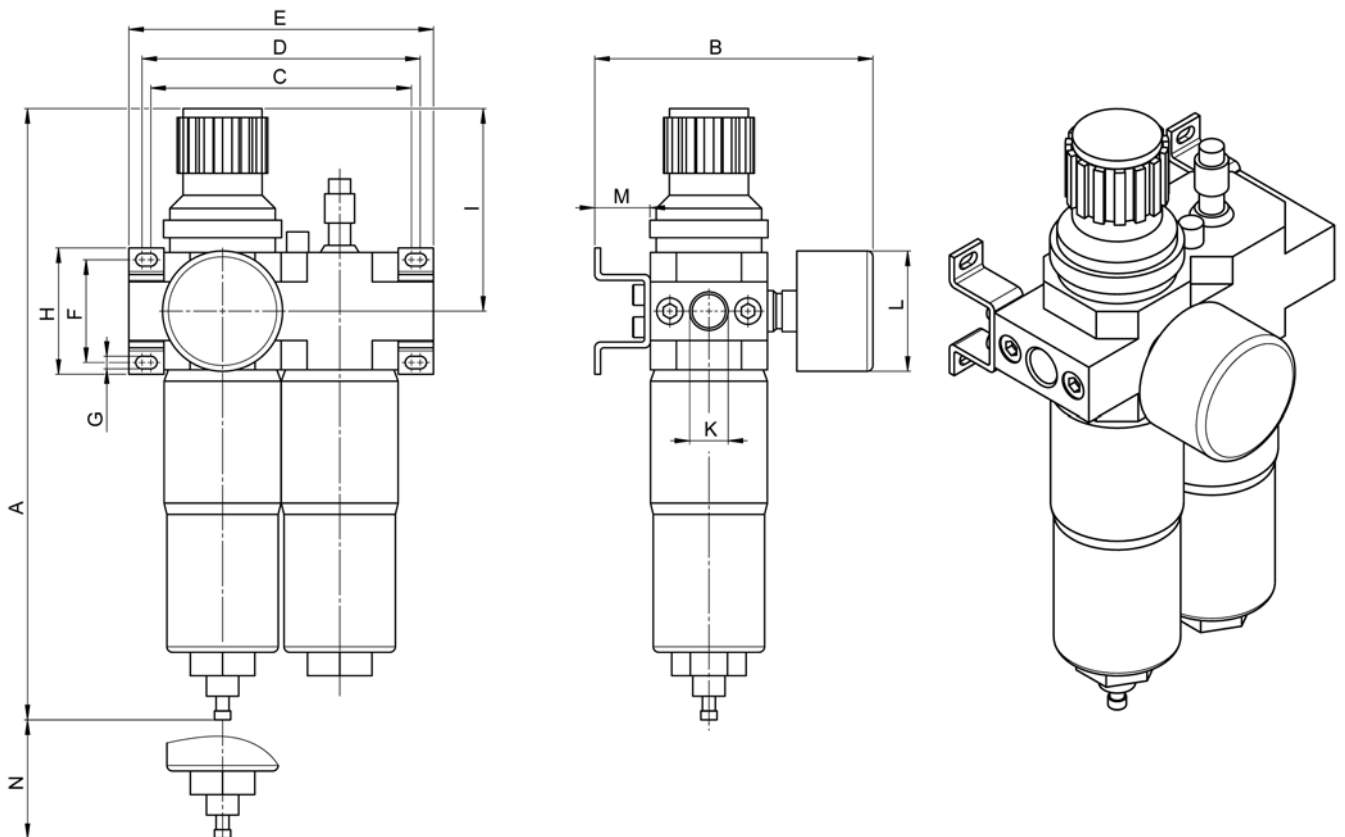

2. Regulator

Data

Type	Order. No.	Nominal diameter/ connection	Perm. pressure range [bar]	Input pressure max. [bar]	Flow [l/min]	Weight [kg]	Filter [µm]
NFR 1/4	81885014	G 1/4	0,5 - 7	16	1.200	0,46	5
NFR 3/8	81885038	G 3/8	0,5 - 7	16	2.400	0,90	5
NFR 1/2	81885012	G 1/2	0,5 - 7	16	7.500	1,37	5
NFR 1	81886100	G 1	0,5 - 7	16	10.000	1,47	40

All regulators with manual outlet valve, manometer, connecting angle and filter cartridge

Dimensions [mm]

Type	A	B	C	D	E	F	G	H	I	K	L	M	N
NFR 1/4	211	95	49	55	64	35	4,3	43	72	G ¼	41	19	80
NFR 3/8	268	114	67	73	84	60	5,3	70	102	G ⅜	50	19	85
NFR 1/2	270	121,5	77	83	94	60	5,3	70	85	G ½	49	19	95
NFR 1	270	121,5	88	94	105	60	5,3	70	85	G 1	49	19	95

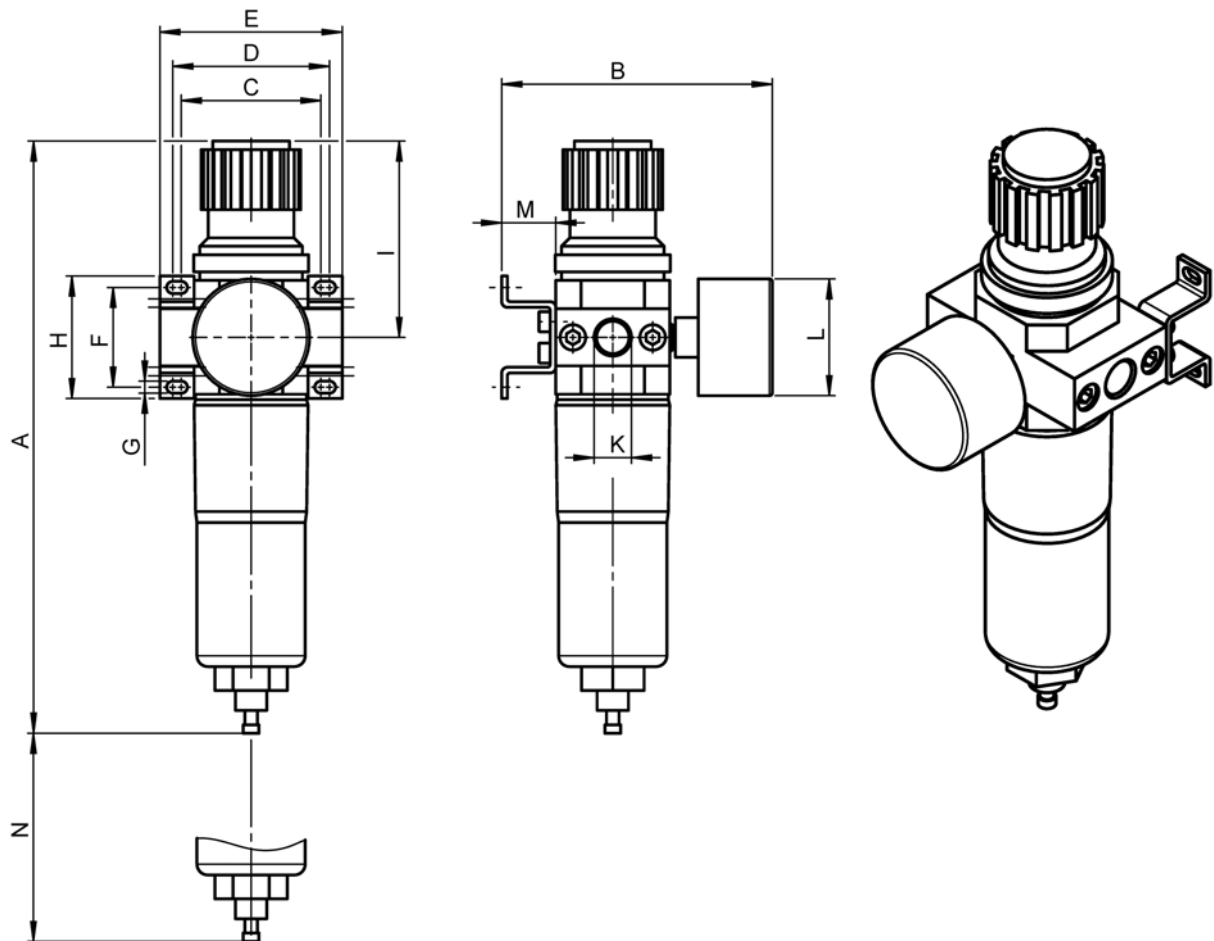

3. Lubricator

Data

Type	Order-No.	Nominal diameter/ connection	Perm. pressure range [bar]	Input pressure max. [bar]	Flow [l/min]	Weight [kg]
NOE 1/4	81882014	G $\frac{1}{4}$	0,5 - 7	16	2.300	0,27
NOE 3/8	81882038	G $\frac{3}{8}$	0,5 - 7	16	5.500	0,63
NOE 1/2	81882012	G $\frac{1}{2}$	0,5 - 7	16	8.400	1,10
NOE 1	81882100	G1	0,5 - 7	16	9.000	1,20

All lubricators with connecting angle

Dimensions [mm]

Type	A	B	C	D	E	F	G	H	I	K	M	N
NOE 1/4	169	59	49	55	64	35	4,3	43	45	G $\frac{1}{4}$	19,0	100
NOE 3/8	204	74	67	73	85	60	5,3	70	53	G $\frac{3}{8}$	20,5	120
NOE 1/2	228	85	77	83	96	60	5,3	70	58	G $\frac{1}{2}$	19,5	150
NOE 1	228	85	88	94	116	60	5,9	70	58	G 1	19,5	150

